



Priming Assisted Centrifugal Pump w/ Autostart

Model PA6C604045T /S2 PSO
Size 6" x 6"



SHOWN WITH OPTIONAL CONTAINMENT SKID BASE

PUMP SPECIFICATIONS

Size: 6 x 6" (152 mm x 152 mm) Flanged.
Casing: Ductile Iron 654512. Maximum Operating Pressure 99 psi (683 kPa) . *
Open Type, Two Vane Impeller: Ductile Iron 654512. Handles 3" (76,2 mm) Diameter Spherical Solids.
Impeller Shaft: Stainless Steel 174 PH.
Replaceable Wear Plate: Ductile Iron 806003
Bearing Housing: Gray Iron 30.
Seal Plate: Gray Iron 30.
Seal: Mechanical, OilLubricated. Silicon Carbide Rotating and Stationary Faces. Stainless Steel 316 Stationary Seat. Fluorocarbon Elastomers (DuPont Viton or Equivalent). Stainless Steel 188 Cage and Spring. Maximum Temperature of Liquid Pumped, 160 F (71 C). *

Shaft Sleeve: Stainless Steel 174 PH.
Priming Chamber: Gray Iron 30 Housing w/ Stainless Steel Float and Linkage.
Discharge Check Valve: Ductile Iron Housing w/BunaN Flapper.
Radial/Thrust Bearings: Open Double Ball.
Bearing Lubrication: SAE 30 NonDetergent Oil.
Gaskets: Resistant Synthetic Rubber, Cork, PTFE, Vegetable Fiber, and Compressed Synthetic Fibers.
ORings: Buna-N.
Hardware: Standard Plated Steel. Bearing and Seal Cavity Oil Level Sight Gauges.

Standard Equipment: GearDriven Air Compressor. Hoisting Bail. Rigid Thick Pipeline Frame. Combination Skid Base w/Fuel Tank. 6" Suction Spool. Strainer. Battery. Gauge Kit. Drain Kit. Single Ball Type Float Switch ** .
Optional Equipment: Containment Skid Base. High Speed (55 MPH/89 KM/H) Single Axle PneumaticTired Wheel Kit w/wo DOT-Approved Lights and Electric Brakes.

*Consult Factory for Applications Exceeding Maximum Pressure and/or Temperature Indicated.

** 50 Ft. (15 m) Standard Length; Dual Switches and Alternate Cable Lengths Available From the Factory.

ENGINE SPECIFICATIONS

Model: John Deere 4045T.
Type: Four Cylinder, Four Cycle, Turbocharged, Liquid Cooled Diesel Engine.
Displacement: 276 Cu. In. (4,5 liters).
Governor: Electronic Isochronous.
Lubrication: Forced Circulation.
Air Cleaner: Dry Type.

Oil Reservoir: 17.5 U.S. Qts. (16,6 liters) Dry; 15.5 U.S. Qts. (14,7 liters) Rell.
Fuel Tank: 88 U.S. Gals. (330 liters). Full Load Operating Time: 21.7 Hrs.
Starter: 12V Electric.
Standard Features: Low Oil Pressure and High Coolant Temperature Safety Shut Down Switches/ Indicators. Autostart Instrument Panel

Includes: Tachometer, Voltmeter, Hourmeter, Coolant Temperature Gauge, Oil Pressure Gauge, Manual/Stop/Auto Key Switch, 10 Amp Pushbutton Circuit Breaker, Audible Startup Warning Delay. Muer w/ Guard and Weather Cap. Throttle Control.



Contact Us Today at **1-855-955-CCIS (2247)** or Visit **CrossCountryIS.com**

Specification Data

Priming Assisted Centrifugal Pump w/Autostart
Model PA6C604045T /S2 PSO

NET WEIGHT: 5480 LBS. (2486 KG.)
SHIPPING WEIGHT: 5480 LBS. (2486 KG.)
EXPORT CRATE SIZE: 340 CU. FT. (9,6 CU. M.)

APPROXIMATE DIMENSIONS AND WEIGHTS

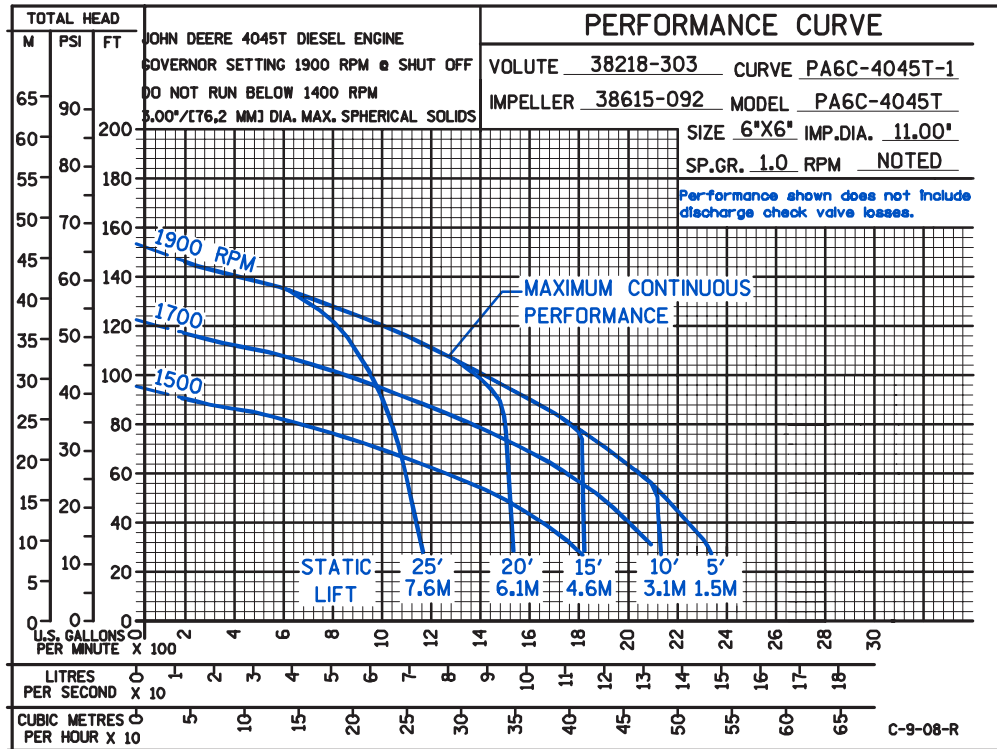
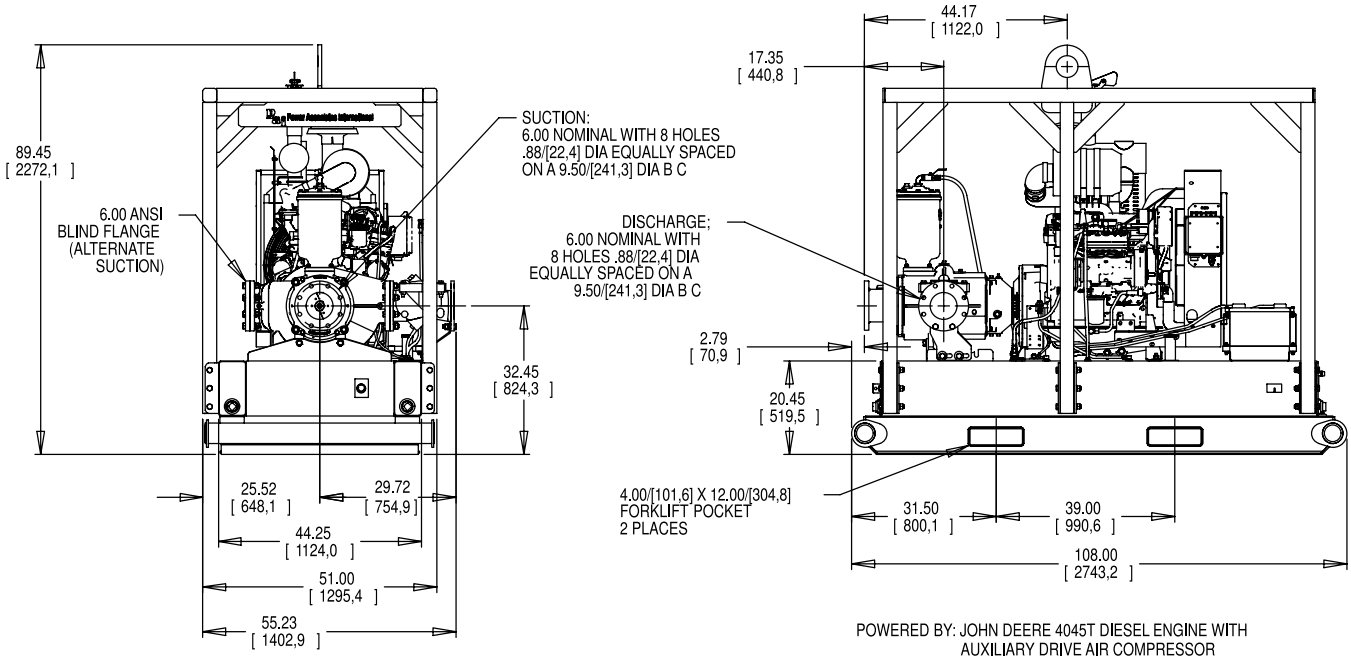

Contact Us Today at 1-855-955-CCIS (2247) or Visit CrossCountryIS.com

