

SCAIP Padding Machine SPD-150 EVO



General Specifications

ENGINE

CAT C4.4 ACERT (TIER 4F- STAGE V)

Type:	Caterpillar
Emission Class	Tier 4 FINAL (U.S. EPA) STAGE V (EU)
Net Horse Power	147 hp 110 kW
Rev Per Minute	2.100 rpm
Displacement	4,4 lt- 268 Cu In

TRANSMISSION

Type	Hydrostatic
Motor	Axial Piston, 1 Speed, Integrated
Brakes	Integrated Multiple Disk Brake, Negative Control
Final Drive	Planetary, In Oil Bath
Max Speed	3,5 Km/H - 2.2 Miles/Hr
Pumps	2 Independent, Variable Pumps
Max. Operating Pressure	350 Bar
Max. Flow Rate	132 l/Min - 35 Us Gal/Min

VIBRATING SCREEN

Type	Hydrostatic
Interchangeable Mesh	From 1/2" To 4" (Other Mesches Type On Demand)
Width	1400 Mm - 55 In
Length	1700 Mm -113 In
Area	2,3.M2 - 25 Sq Ft
No. Screening Levels	1
Max. Speed	From 800 To 1050 Rpm @2.100 Rpm Engine

LOAD COVEYOR

Type	Hydrostatic, Variable Speed Control
Track Chain	Axial Piston, Fixed Displacement
Max. Operating Pressure	250 Bar
Max. Operating Flow	80 l/Min - 21 Us Gal/Min
Undercarriage	Planetary, In Oil Bath
Pumps	2 Independent, Variable Pumps
Rotation	Reversible
Chain	Two, Tractor Type
Max. Shoe Width	1.165 mm - 46 Inc.
Max. Stroke ↓	250 mm -10 Inc
Max. Stroke ↑	780 mm - 31 Inc

UNLOADING CONVEYOR

Type	Two-Side Belt With Hydraulically- Controlled Extension
Belt Type	Rubber
Rotation	Reversible
Width	500 mm - 20 in
Length	4.500 mm -177 in
Variable Speed	0-430 m/min
Transmission	Hydrostatic, Variable Speed
Hydraulic Motors	Type 2, Orbital

ELECTRICAL SYSTEM

Operating Voltage	24V
Batteries	Nº 2 - 100 Ah
Starter	4,5 KW
Alternator	85A

TRACKED CARRIAGE

Bottom Rollers	6 Per Side
Top Rollers	2 Per Side
Track Gauge	2.120 mm - 83 in
Pitch	2.350 mm - 92.5 in
Shoe Material	STEEL
Shoe Width	400 mm - 15.75 in
Area In Contact With Ground	18.800 cm2 - 2914 sq.in
Specific Pressure On Ground	0.74 kg/cm2 -10.5 lb /sq.in
Admissible Longitudinal Slope	35% {22°}
Admissible Transverse Slope	28% (5°)

WEIGHT

Operating Weight	13,960 kg / 30,780 lb
------------------	-----------------------

DIMENSIONS

Length	6800 mm - 268 in
Min. Width	2550 mm -100 in
Max. Width	4950 mm -195 in
Height	3320 mm -131 in

SPD-150 EVO

Dimensions

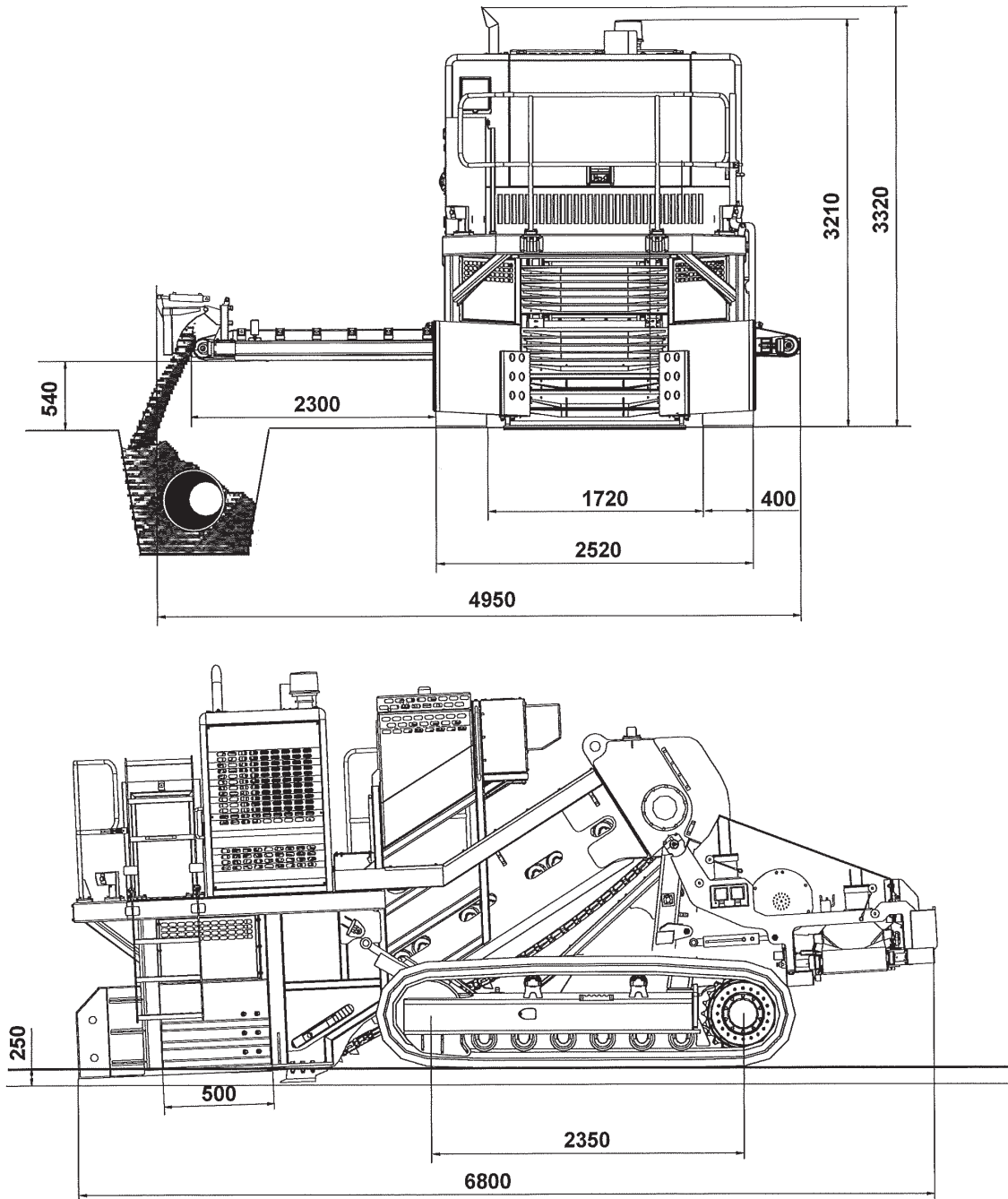

For Pricing And Availability Contact Our Sales Team at 1-855-955-CGIS (2247)

