

SCAIP Padding Machine SPD-450 EVO



General Specifications

DIESEL ENGINE

CATERPILLAR C13

Type:	Caterpillar
Net Flywheel Power	440 HP - 328 kW
Engine Revolutions	2,100 rpm
Emissions	Tier 4 final / STAGE V

HYDRAULIC SYSTEM

Drive Pumps	#2 independent, variable displacement piston pumps
Max. Flow Rate	250 l/min 66 U.S. Gal/min
Max. Pressure	320 bar 4640 p.s.i.
Escalator Pump	#1 variable displacement piston pump
Max. Flow Rate	250 l/min 66 U.S. Gal/min
Max. Pressure	280 bar 4060 p.s.i.
Main Service Pump	#1 variable displacement piston pump featuring load sensing
Max. Flow Rate	150 l/min 40 U.S. Gal/min
Max. Pressure	300 bar 4350 p.s.i.
Service Pump	#3 gear pumps

SCREEN

Width	2400 mm / 8 in
Length	3070 mm / 11" inc
Screen Area	8 M ² / 86 Sq Ft ²
No. Screening Levels	1
Screening Capacity (2"Mesh)	209 m ² /h / 7385 ft ² /h

ESCALATOR

Type	Hydrostatic, Variable Speed Control
Motors	#1 fixed displacement piston motors
Final Drives	epicycloid, oil bath
Rotation	reversible
Chain	double
Shoes	1980 mm / 6'1/2" in
Max. Speed	80 m/min 262 ft/min
Blade Depth (From Ground)	350 mm / 13.5 in
Max. Blade Height (From Ground)	1510 mm / 60 in
Escalator Capacity*	174 m ³ /h / 6148 ft ³ /h

*the output capacity mentioned here is just an indication as it depends on different factors such as the type of soil, moisture content, etc.

UNLOADING CONVEYOR

Variable Speed	0-230 m/min / 1443 ft/min
Width	900 mm / 35 in
Length	7.80 m / 26 ft

TANK CAPACITY

Fuel Tank	725 L / 193 Gal
Hydraulic System Tank	785 L / 209 Gal

ELECTRICAL SYSTEM

Operating Voltage	24V
No. Of Maintenance Free Batteries	2
Capacity (Total)	2x180 Ah
Starter Motor Power	7.5kw

TRACKED CARRIAGE

Bottom Rollers	2
Top Rollers	8
Width Of Tracks	3,050 mm 120 in
Distance Between Tracks	4,070 mm 160 in
Shoe Width	700 mm 27.5 in
Area In Contact With Ground	56,980 cm ² 8,832in ²
Specific Pressure On Ground (Loadless)	0.95 kg/ cm ² 13.5 lbs/in ²

WEIGHT

Operating Weight	55,200 kg / 121,700 lbs
------------------	-------------------------

DIMENSIONS

Length	13.1 m / 43 ft
Width	3.8 m / 12.5 ft
Height min	3.8 m / 12.5 ft

SPD-450 EVO

Dimensions



2.3. Overall dimensions

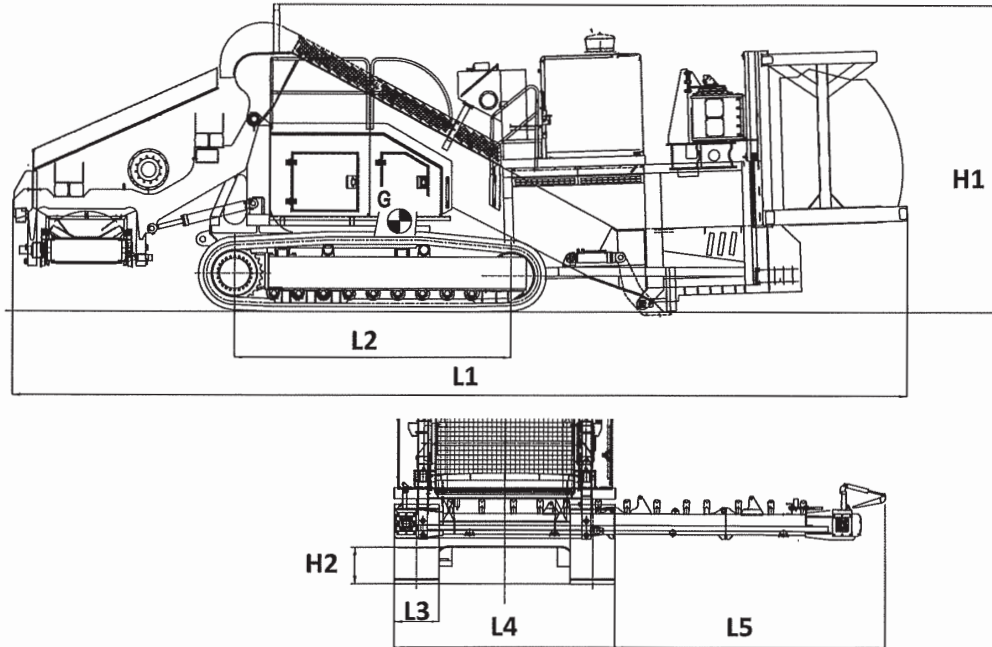

POS	DIMENSION			
L1	13,3	m	43.0	ft
L2	4,07	m	13.3	ft
L3	0,7	m	2.3	ft
L4	3,8	m	12.5	ft

POS	DIMENSION			
L5	5,0	m	16.0	ft
H1	4,2	m	14.0	ft
H2	0,53	m	1.7	ft

For Pricing And Availability Contact Our Sales Team at 1-855-955-CGIS (2247)

