

SCAIP Bending Machines



FEATURES

Quick connection for Hydraulic Mandrel

Accessories **ACCURACY BEND**

System was conceived for the measurement of pipe-line's bending angles.



Load Sensing

To control the movement proportionally.

Bending Set

Winch



For Pricing And Availability Contact Our Sales Team at 780-962-6559 or Visit CrossCountryIS.com/scaip



The Right Product & Service **Every Time**

SCAIP Pipe Bending Machine Models



SPB 6-20 HD



Operating
Weight 6 t /
13,200 lb

Net Flywheel
Power 62 hp
/ 46 Kw

SPB 16-30



Operating
Weight 18,5 t
/ 40,700 lb

Net Flywheel
Power 142
hp / 106 Kw

SPB 22-36



Operating
Weight 27 t /
59,520 lb

Net Flywheel
Power 142
hp / 106 Kw

SPB 32-42



Operating
Weight 43,5 t
/ 96,000 lb

Net Flywheel
Power 225
hp / 168 Kw

SPB 36-48



Operating
Weight 68 t /
151,000 lb

Net Flywheel
Power 225
hp / 168 Kw

SPB 48-60



Operating
Weight 96 t /
211,200 lb

Net Flywheel
Power 225
hp / 168 Kw

SCAIP Wedge Mandrels

Modern technologies for reliable and efficient products

Our hydraulic wedge mandrels are made of very high quality. They are supplied complete with extension pipes and sets of shims for registration. The SWH series covers pipe diameters between 10" and 60". From 10" to 22" mandrels are available in both manual and motorized versions, while 24" mandrels onwards are only available in the motorized version. Bending set from 6" to 60".

Model Numbers

SWH 10 SWH 12-14 SWH 16-18 SWH 20-22 SWH 24-28 SWH 30-36
SWP 40-42 SWH 40-42 SWP 46-48 SWH 50-60 SWH 46-48



**For Pricing And Availability Contact Our Sales Team at 780-962-6559
or Visit CrossCountryIS.com/scaip**

SPECIFICATIONS

DIESEL ENGINE	32-42	36-48	48-60
BRAND	Caterpillar	Caterpillar	Caterpillar
MODEL	C7.1 ACERT	C7.1 ACERT	C7.1 ACERT
EMISSION	U.S. EPA Tier 4 / EU Stage V	U.S. EPA Tier 4 / EU Stage V	U.S. EPA Tier 4 / EU Stage V
NO. OF CYLINDERS	6	6	6
ENGINE BORE	105 mm - 135 mm	105 mm - 135 mm	105 mm - 135 mm
DISPLACEMENT	7,01 L	7,01 L	7,01 L
COMPRESSION RATIO	16,5:1	16,5:1	16,5:1
POWER ACCORDING TO ISO STANDARD DIN 6271	225 HP - 168 kW	225 HP - 168 kW	225 HP - 168 kW
ENGINE REVOLUTIONS PER MINUTE	2100 RPM	2100 RPM	2100 RPM
CONTROL VALVE	32-42	36-48	48-60
BRAND	Rexroth	Rexroth	Rexroth
TYPE	load-sensing with proportional control (LUDV)	load-sensing with proportional control (LUDV)	load-sensing with proportional control (LUDV)
SPOOLS	N.5	N.6	N.6
HYDRAULIC OIL TANK	32-42	36-48	48-60
TYPE	metal work with filter	metal work with filter	metal work with filter
CAPACITY	121 US. Gal. - 460 L	121 US. Gal. - 460 L	121 US. Gal. - 460 L
FUEL TANK	32-42	36-48	48-60
TYPE	metal work with filter	metal work with filter	metal work with filter
CAPACITY	76 US. Gal. - 290 L	76 US. Gal. - 290 L	76 US. Gal. - 290 L
HYDRAULIC WINCH	32-42	36-48	48-60
TYPE	2.280.0017	2.280.0019	2.280.0019
MAX. PULL AT 1ST LAYER	7.850 kg	15.000 kg	15.000 kg
HYDRAULIC MOTOR	orbital DANFOSS	orbital DANFOSS	orbital DANFOSS
FRAME	aluminum alloy + ductile cast iron	aluminum alloy + ductile cast iron	aluminum alloy + ductile cast iron
REDUCTION GEAR	with worm screw, irreversible	with worm screw, irreversible	with worm screw, irreversible
NEUTRAL	manual	manual	manual
MAX. OPERATING PRESSURE	130 bar - 1.885 PSI	150 bar - 2.175 PSI	150 bar - 2.175 PSI
MAX. FEED FLOW RATE	100 L/min - 26 US Gal/min	160 L/min - 42 US Gal/min	160 L/min - 42 US Gal/min
SPEED AT 1ST LAYER	16 ft/min - 4,85 mt/min	16 ft/min - 4,85 mt/min	16 ft/min - 4,85 mt/min
RECOMMENDED CABLE DIAMETER	1/2 inch - Ø 13 mm	3/4 inch - Ø 19 mm	3/4 inch - Ø 19 mm
WIRE ROPE TYPE	6 strands with textile core R= 2160 N/mm ² min. breaking load guaranteed 15700 kg	6 strands with textile core R= 2160 N/mm ² min. breaking load guaranteed 30000 kg	6 strands with textile core R= 2160 N/mm ² min. breaking load guaranteed 30000 kg

DIMENSIONS

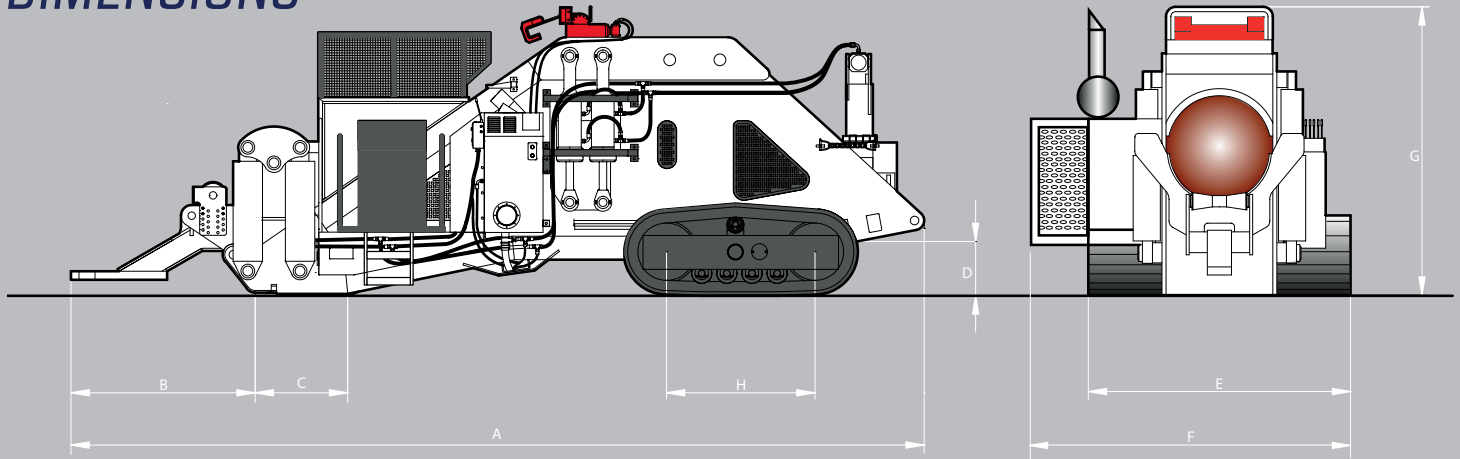

DIMENSIONS	32-42	36-48	48-60
A	8900 mm - 29 ft	10125 mm - 36 ft	11000 mm - 36.1 ft
B	2000 mm - 6.5 ft	2130 mm - 7 ft	2000 mm - 6.5 ft
C	1350 mm - 4.4 ft	1585 mm - 5.2 ft	1550 mm - 5 ft
D	390 mm - 1.2 ft	413 mm - 1.3 ft	435 mm - 1.4 ft
E	3000 mm 10 ft	3410 mm - 11 ft	3940 mm - 11.4 ft
F	3250 mm - 10.5 ft	3500 mm - 11.4 ft	4015 mm - 13 ft
G	3000 mm - 10 ft	3240 mm - 10.5 ft	3815 mm - 12.5 ft
H	1500 mm - 5 ft	1790 mm - 5.8 ft	2434 mm - 7.9 ft
WEIGHT	43.500 kg - 96.000 lb	68.000 kg - 151.000 lb	96.000 kg - 211.200 lb

Example of SCAIP High Bending Strength

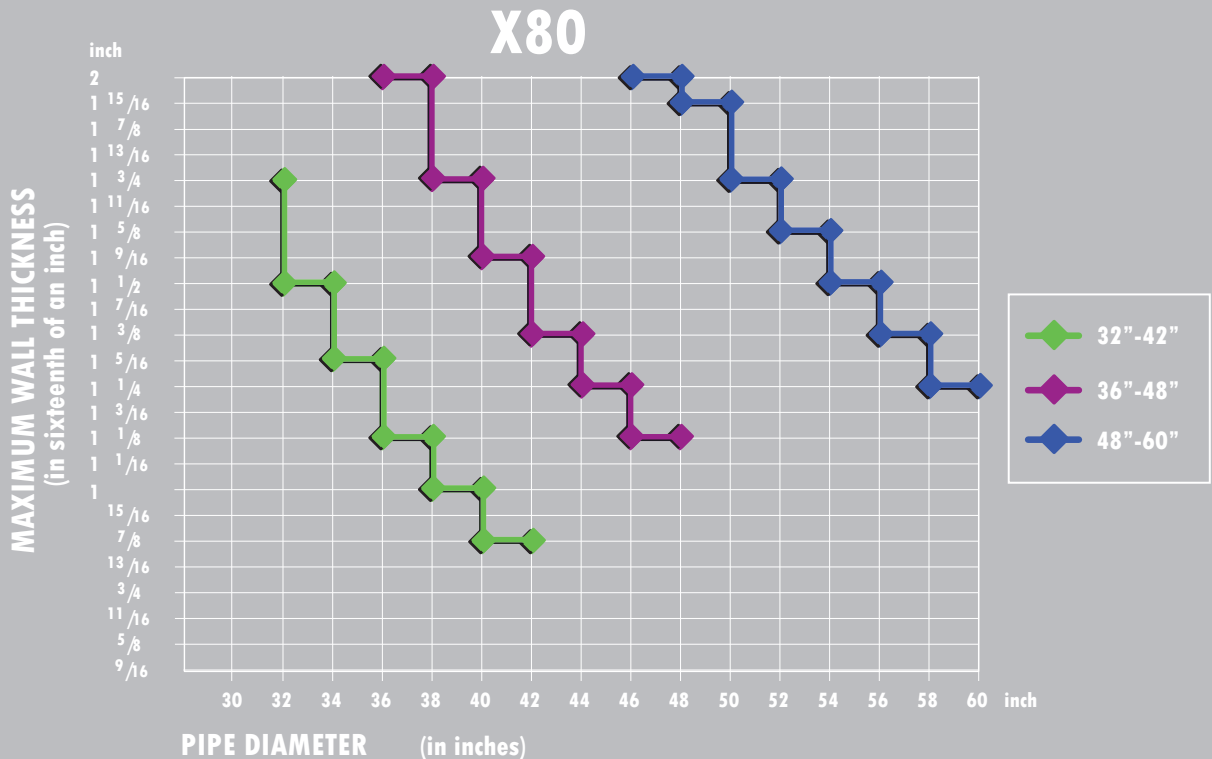

The bending performance data shown was calculated using API X80 as an example.